

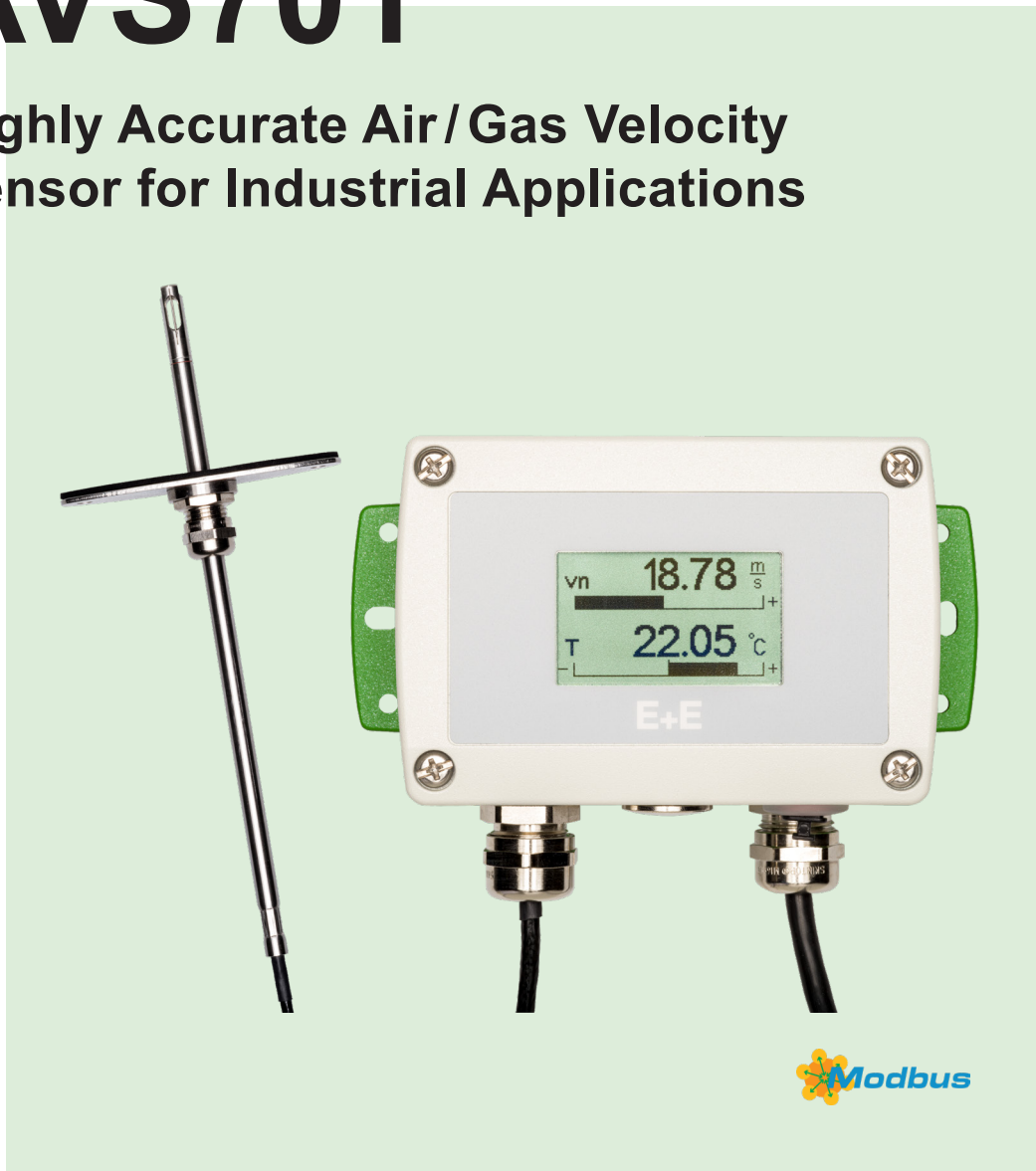

—  
your partner  
in sensor  
technology.

# + Datasheet AVS701

Highly Accurate Air / Gas Velocity  
Sensor for Industrial Applications



# AVS701

## Highly Accurate Air/Gas Velocity Sensor for Industrial Applications

The AVS701 air/gas velocity ( $v$ ) and temperature ( $T$ ) sensor is optimised for best measurement results and reliability in challenging industrial applications from 0 up to 40 m/s (0 to 8 000 ft/min) and  $-40\dots+140\text{ }^{\circ}\text{C}$  ( $-40\dots+284\text{ }^{\circ}\text{F}$ ).

### Measurement Performance

The AVS701 features best-in-class accuracy and durability by employing a high-end ceramic sensing element. The constant temperature anemometry working principle rests on the state-of-the-art thin film technology. The probe alignment key included in the scope of supply is essential to achieve excellent measurement results. This Poka-Yoke-inspired mounting tool simplifies the quick and correct installation of the remote probe.

### Long-Term Stability

The robust probe design and the E+E sensing element construction significantly extend the service lifetime of the AVS701. Probe and sensor head are made of stainless steel, suitable for challenging mechanical and chemical environment. A proprietary coating protects the sensing element against corrosion and aggressive substances.

### Versatility

The AVS701 is available for wall or duct mount as well as with remote probe. The remote probe features various cable lengths and pressure rating up to 10 bar (145 psi). The modular IP65 polycarbonate or die-cast aluminium enclosure facilitates installation and maintenance. The wiring can be done either via M12 connectors or directly to internal terminals.

### Display and Outputs

The measured data is available on two analogue outputs and on the RS485 interface with Modbus RTU protocol. The display shows up to three measurands simultaneously. Measurand visualization via linear gauges with configurable upper and lower limits gives a quick view onto the actual process status. Optical indication of sensor and measurement status facilitates diagnosis for AVS701 without display.

### Configurable and Adjustable

AVS701 configuration and adjustment can be performed with the free PCS10 Product Configuration Software and the USB interface.



Wall mounting version with remote probe, die-cast enclosure

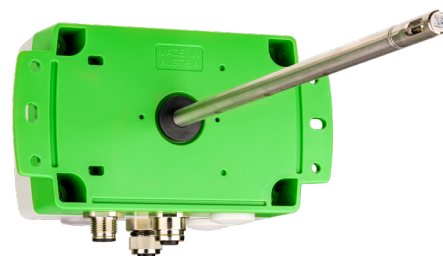

Duct mount version, polycarbonate enclosure

# Features

## Measurement performance

- Best-in-class accuracy
- Measuring range -40...+140 °C (-40...+284 °F) and up to 10 bar (145 psi)

## Display

- Shows up to 3 measurands simultaneously
- Freely selectable layout and measurands
- Linear gauges for quick perception

## Enclosure

- IP65 protection rating
- Polycarbonate or die-cast aluminium
- Easy mounting and service
- Versatile connection options

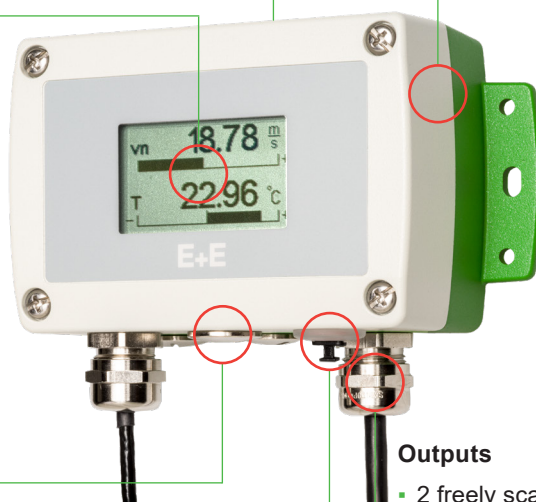

## Sensor control port

- Connector for external pressure probe (optional)
- Realtime pressure compensation

## USB-C service interface

- Configuration, adjustment and firmware update
- Short-term power supply via USB
- Device status indication via illuminated port

## Outputs

- 2 freely scalable analogue outputs, current/voltage
- Error indication according to NAMUR
- Modbus RTU
- 2 alarm outputs
- Configurable via software

## Sensing element

- Accurate air velocity measurement from 0.06 m/s to 40 m/s (12 to 8000 ft/min)
- Low angular dependency
- Long-term stability

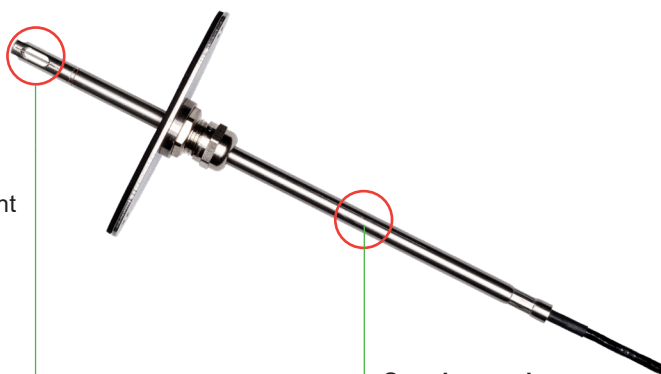

## Sensing probe

- Poka-Yoke inspired probe alignment key
- Probe choice depending on
  - T range
  - p range
  - Environmental condition
- Various probe and cable lengths

## Inspection certificate

According to DIN EN 10204-3.1

# Features

## Sensing Element Protection

Proprietary hermetic polymer coating (varnish) protects the sensing element from corrosion in demanding environment and substantially extends sensor lifetime in applications with H<sub>2</sub>O<sub>2</sub> sterilisation.

## Sensor Control Port

The sensor control port is an RS485 interface with Modbus RTU protocol for the optional external pressure probe. The pressure data allow for the realtime calculation of the actual flow, can be shown on the display and is available on the outputs. A suitable pressure probe is available as an accessory.

## Accredited Traceable Calibration Certificate



Internationally recognised certificates for the calibration of measuring instruments from accredited laboratories document the traceability of the measurements to the International System of Units (SI). The E+E Elektronik calibration laboratory offers two levels of traceable calibrations.

- As a Designated Institute (DI) of the Republic of Austria, the E+E calibration laboratory maintains Austria's national measurement standards for humidity, dew point temperature, air velocity and CO<sub>2</sub>. This authorises the E+E calibration laboratory to issue calibration certificates at the level of a National Metrological Institute (NMI).
- The E+E calibration laboratory is accredited by Akkreditierung Austria in accordance with DIN EN ISO/IEC 17025 with the identification number 0608. This allows the laboratory to issue ISO 17025 certificates for the measurands humidity, temperature, dew point temperature, air velocity, flow, pressure and CO<sub>2</sub>.

Visit [www.eplusecal.com](http://www.eplusecal.com) for detailed information on calibration and to enquire a certificate of accredited traceable calibration for the AVS701 from the Designated Institute.

## ISO 9001 Calibration Certificate

An ISO 9001 calibration certificate documents the comparative measurement of a device against high quality reference equipment (factory level standard). The comparison is performed in accordance with internal procedures that comply with ISO 9001 and provides information on the specimen's measuring accuracy. The reference equipment is traceable to national standards, however, the calibration process is not accredited. Therefore, an ISO 9001 calibration is neither traceable nor internationally comparable.

Visit [www.epluse.com/iso9001cal](http://www.epluse.com/iso9001cal) for detailed information on calibration and to enquire an ISO 9001 calibration certificate.

# Dimensions

Values in mm (inch)

## Enclosure

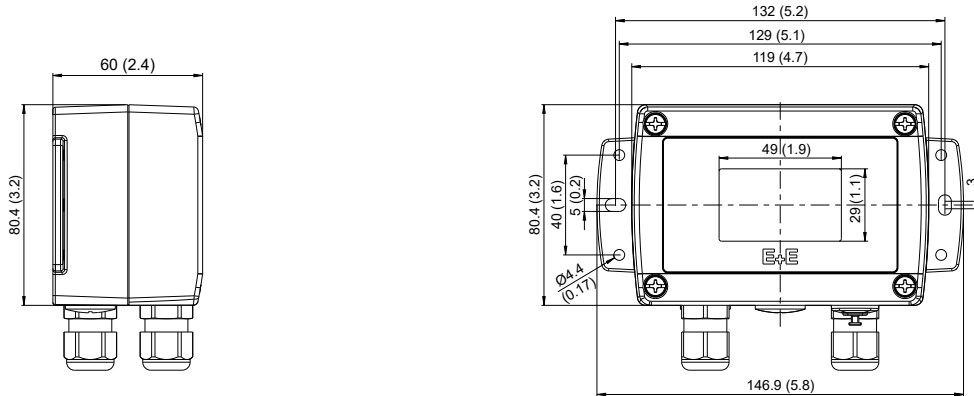

## Connector side view

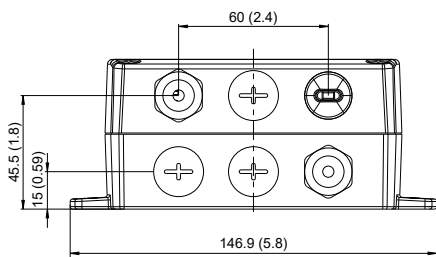

## Type T2 Duct mount

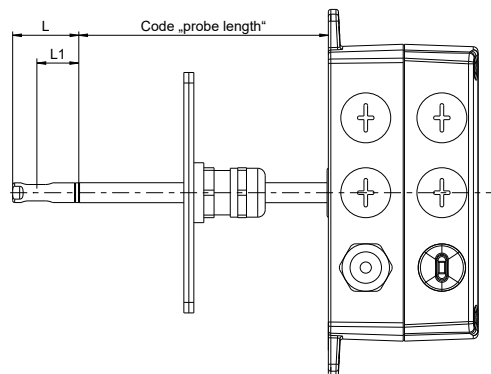

Sensing head	L	L1
Stainless steel	26.5 (1.04)	16.8 (0.66)

# Dimensions

Values in mm (inch)

## Type T3 Probe

Remote probe

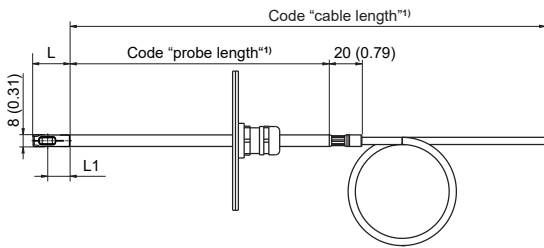

## Type T26 Probe

Remote probe, pressure-tight up to 10 bar (150 psi) with cut-in fitting

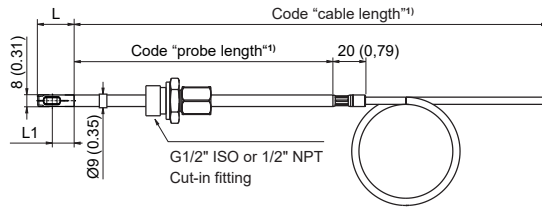

1) Refer to ordering guide

## Mounting flange

Within scope of supply for T2 and T3

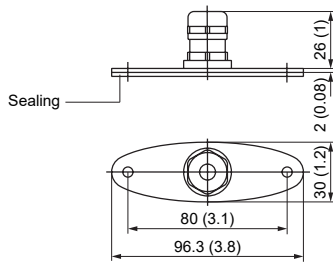

## Probe alignment key

Poka-yoke inspired tool, only one direction possible  
Within scope of supply for types T3 and T26

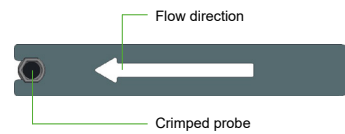

# Technical Data

## Measurands

### Air Velocity Standardised (vn)

<b>Measuring range</b>	0...2 m/s (0...400 ft/min) 0...15 m/s (0...3 000 ft/min) 0...40 m/s (0...8 000 ft/min)	
<b>Accuracy</b> in air at 23 °C (73 °F) and 1 013 mbar (14.7 psi), including non-linearity, hysteresis and repeatability <b>0.06...2 m/s (12...400 ft/min)</b> <b>0.15...15 m/s (30...3 000 ft/min)</b> <b>0.20...40 m/s (40...8 000 ft/min)</b>	±0.03 m/s (6 ft/min) ±(0.10 m/s (20 ft/min) + 1 % of mv) ±(0.20 m/s (40 ft/min) + 1 % of mv)	mv = measured value
<b>Uncertainty of factory calibration</b>	±1 % of mv, min. 0.015 m/s (3 ft/min)	mv = measured value
<b>Dependency of inflow angle (α)</b>	<3 % for α < ±10°	
<b>Influence of the reverse flow, typ.</b>	<2 % of mv	mv = measured value
<b>Response time t<sub>90</sub>, typ.</b>	0.1...35 s (Factory setting: 1.7 s; configurable via <a href="#">PCS10</a> in 9 steps)	
<b>Temperature dependency of electronics, typ.</b>	±0.01 % of mv/K deviating from 25 °C (77 °F)	mv = measured value
<b>Temperature dependency of probe, typ.</b>	±0.1 % of mv/K deviating from 25 °C (77 °F)	mv = measured value
<b>Warm-up time</b>	<5 s	

### Temperature (T)

<b>Measuring range</b>	-40...+140 °C (-40...+284 °F)	
<b>Accuracy</b> in air at 23 °C (73 °F) at vn ≥1 m/s (200 ft/min)	±0.5 °C (±0.9 °F)	
<b>Temperature dependency of electronics, typ.</b>	±0.005 % of mv/K, deviating from 25 °C (77 °F)	mv = measured value
<b>Temperature dependency of probe, typ.</b>	±0.1 % of mv/K, deviating from 25 °C (77 °F)	mv = measured value
<b>Response time t<sub>90</sub>, typ.</b>	≤10 s	

## Outputs

### Analogue

<b>Two freely selectable and scalable outputs</b> for vn, T, V'n	0 - 10 V 0 - 20 mA / 4 - 20 mA (3-wire)	-1 mA < I <sub>L</sub> < 1 mA R <sub>L</sub> ≤ 350 Ω	I <sub>L</sub> = load current R <sub>L</sub> = load resistance
<b>Accuracy</b> @23 °C (68 °F)	±0.05 % FS		FS = full scale (20 mA, 10 V)
<b>Temperature dependency<sup>1)</sup></b>	±0.005 % FS / °C		FS = full scale (20 mA, 10 V)
<b>NAMUR Factory settings</b>	11 V or 21 mA		

1) Deviating from 23 °C (68 °F), defined at 12 mA or 5 V, respectively

### Digital



<b>Digital interface</b> <b>Protocol</b> <b>Factory settings</b> <b>Supported Baud rates</b>	RS485 (AVS701 = 1 unit load) Modbus RTU 9 600 Baud, 8 data bits, parity none, 1 stop bit, Modbus address 47 9 600, 19 200, 38 400, 57 600, 76 800 and 115 200
---	--

### Switching Outputs (Optional)

<b>2 switching outputs</b>	Potential-free (Opto-MOS)
<b>Switching capacity</b>	Max. 24 V DC, 1 A

# Technical Data

## General

<b>Power supply</b> class III  USA & Canada: Class 2 supply necessary	24 V DC ±20 %
<b>Current consumption</b> <b>Typ. With Display</b>	<100 mA <160 mA
<b>Electrical connection</b>	M12x1 plug or via M16 cable gland to internal terminals
<b>Temperature working range</b> <b>Probe and sensing element</b> <b>Probe cable</b> <b>Enclosure</b> <b>Enclosure with display</b>	-45...+160 °C (-40...+320 °F) <sup>1)</sup> -40...+180 °C (-40...+356 °F) -40...+60 °C (-40...+140 °F) -30...+60 °C (-22...+140 °F)
<b>Pressure working range</b> <b>T2, T3</b> <b>T26</b>	700...1300 mbar (10.2...18.9 psi) Pressure-tight 0.05...10 bar (0.73...145 psi)
<b>Humidity working range</b>	0...99 %RH, non-condensing
<b>Storage conditions</b>	-20...+70 °C (-4...+158 °F) 0...95 %RH, non-condensing
<b>Protection rating</b>	IP65/NEMA 4X
<b>Material</b> <b>Probe incl. head</b> <b>Probe cable jacket</b> <b>Sensing element</b> <b>Enclosure</b>	Stainless steel 1.4404 PTFE (Polytetrafluoroethylene) Ceramics with polymer finish Die-cast aluminium AlSi9Cu3 or PC (Polycarbonate)
<b>Electromagnetic compatibility</b>	EN 61326-1      EN 61326-2-3      Industrial Environment FCC Part15 Class B      ICES-003 Class B
<b>Configuration und adjustment</b>	<a href="#">PCS10</a> via USB
<b>Conformity</b>	 

1) Without power supply

# Ordering Guide

Feature	Description	Code		
		<b>AVS701-</b>		
<b>Type</b>	Duct mount	<b>T2</b>		
	Remote probe		<b>T3</b>	
	Remote probe, pressure-tight, 10 bar (145 psi)			<b>T26</b>
<b>Enclosure material</b>	PC (Polycarbonate)	<b>HS1</b>		
	Die-cast aluminium (AlSi9Cu3)	<b>HS3</b>		
<b>Process connection</b>	G 1/2" ISO - cut-in fitting, Ø8 mm (0.31")			<b>PA29</b>
	1/2" NPT - cut-in fitting, Ø8 mm (0.31")			<b>PA30</b>
<b>Measuring range</b>	0..2 m/s (0..400 ft/min)		<b>HV23</b>	
	0..15 m/s (0..3000 ft/min)	<b>HV27</b>	<b>HV27</b>	<b>HV27</b>
	0..40 m/s (0..8000 ft/min)	<b>HV30</b>	<b>HV30</b>	<b>HV30</b>
<b>Probe length</b>	100 mm (3.94")	<b>L100</b>	<b>L100</b>	
	200 mm (7.87")	<b>L200</b>	<b>L200</b>	<b>L200</b>
	400 mm (15.75")	<b>L400</b>	<b>L400</b>	<b>L400</b>
	600 mm (23.62")		<b>L600</b>	<b>L600</b>
<b>Probe cable length (incl. probe length)</b>	2 m (6.6 ft)		<b>K2</b>	<b>K2</b>
	5 m (16.4 ft)		<b>K5</b>	
	10 m (32.8 ft)		<b>K10</b>	<b>K10</b>
<b>Display</b>	Without display	<b>No code</b>		
	Display with backlight	<b>D2</b>		
<b>Electrical connection</b>	Cable glands	<b>No code</b>		
	1 plug for power supply and outputs	<b>E4</b>		
	1 plug for power supply + outputs and 1 socket for RS485	<b>E6</b>		
	1 M12 plug, 4 poles, for RS485 (with A0 only)	<b>E9</b>		
<b>Analogue output</b>	0 - 10 V or 4 - 20 mA <sup>1)</sup>	<b>No code</b>		
	No analogue output (does not require the analogue output configuration)	<b>A0</b>		
<b>Digital interface</b>	RS485 with Modbus RTU	<b>J3</b>		
<b>Sensor control port</b>	Without sensor control port	<b>No code</b>		
	Modbus RTU via M12 socket	<b>SCP1</b>		
<b>Additional module</b>	Without additional module	<b>No code</b>		
	2 potential-free switching outputs with cable gland	<b>AM10</b>		

Hardware Configuration

1) Applies to both analogue outputs.

# Ordering Guide (cont'd)

Feature	Description	Code	
Output signal	0 - 10 V <sup>1)</sup>	GA3	
	4 - 20 mA <sup>1)</sup>	GA6	
	RS485 digital interface	No code	
Output 1 measurand	Temperature T	[°C]	No code
	Temperature T	[°F]	MA2
	Air velocity v	[m/s]	MA20
	Air velocity v	[ft/min]	MA21
	Air velocity standardised vn <sup>2)</sup>	[m/s]	MA22
	Air velocity standardised vn <sup>2)</sup>	[ft/min]	MA23
	Volume flow standardised V'n	[m <sup>3</sup> /min]	MA84
	Volume flow standardised V'n	[ft <sup>3</sup> /min]	MA87
	Volume flow V'	[m <sup>3</sup> /min]	MA89
	Volume flow V'	[ft <sup>3</sup> /min]	MA90
Output 1 scaling low	0	No code	
	Value	SALValue	
Output 1 scaling high	50	No code	
	Value	SAHValue	
Output 2 measurand <sup>3)</sup>	Air velocity standardised vn <sup>2)</sup>	[m/s]	No code
	Air velocity standardised vn <sup>2)</sup>	[ft/min]	MB23
	Air velocity v	[m/s]	MB20
	Air velocity v	[ft/min]	MB21
	Temperature T	[°C]	MB1
	Temperature T	[°F]	MB2
	Volume flow standardised V'n	[m <sup>3</sup> /min]	MB84
	Volume flow standardised V'n	[ft <sup>3</sup> /min]	MB87
	Volume flow V'	[m <sup>3</sup> /min]	MB89
	Volume flow V'	[ft <sup>3</sup> /min]	MB90
Output 2 scaling low	0	No code	
	Value	SBLValue	
Output 2 scaling high	40	No code	
	Value	SBHValue	
Medium 1	Air	No code	
	Nitrogen	MUA2	
	CO <sub>2</sub>	MUA3	
	Argon	MUA7	
Medium 2 <sup>4)</sup>	No additional medium	No code	
	Air	MUB1	
	Nitrogen	MUB2	
	CO <sub>2</sub>	MUB3	
	Argon	MUB7	
Duct cross section <sup>3)5)</sup>	Factory pre-setting	No code	
	Value in [mm <sup>2</sup> ]	DCValue	
Protocol	Modbus RTU	P1	
Measurand displayed 1	Air velocity v	[m/s]	DA20
	Other		DAxx
Measurand displayed 2	Temperature T	[°C]	DB1
	Other		DBxx
Accredited traceable calibration certificate in accordance with DIN EN ISO/IEC 17025		see <a href="http://www.eplusecal.com">www.eplusecal.com</a>	
ISO 9001 Calibration Certificate		see <a href="http://www.epluse.com/iso9001cal">www.epluse.com/iso9001cal</a>	

1) Applies to both analogue outputs.

2) Standardised air velocity vn at standard conditions (factory setup): Tn = 23 °C (73 °F), pn = 1 013.25 mbar (14.7 psi), settable via PCS10

3) Only in combination with volume flow measurement. Mx89: DC value in mm<sup>2</sup>, Mx90: DC value in inch<sup>2</sup>.

4) Optional. If not applicable, then "No Code".

5) Required for volume flow measurement in RS485 version, value in mm<sup>2</sup>, factory pre-setting 8 000 mm<sup>2</sup> (12.4 inch<sup>2</sup>).

## Code for measurand displayed in the Ordering Guide

Measurand	Unit	Code	
		DAxx / DBxx	
Temperature	T	°C	1
		°F	2
Air velocity standardised	vn	m/s	22
		ft/min	23
Volume flow standardised	V'n	m <sup>3</sup> /min	84
		SCFM	87
Pressure	p	mbar	100
		psi	101



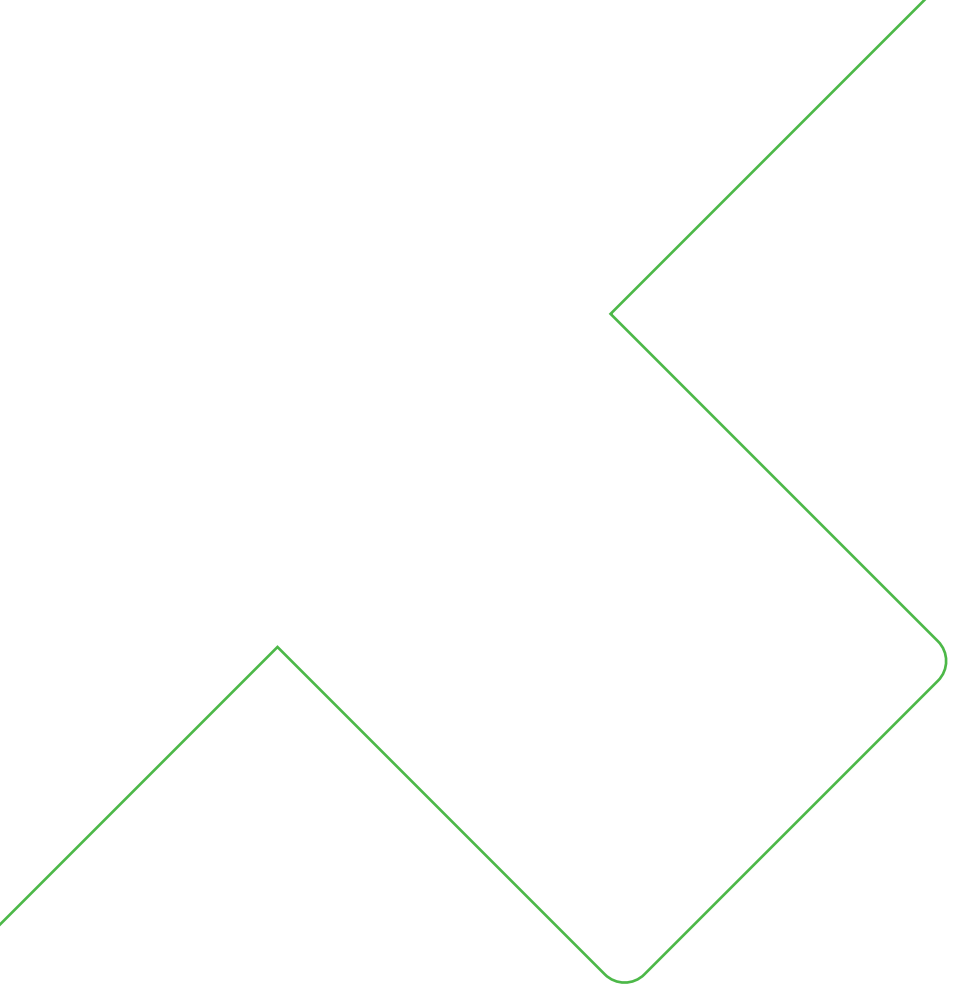

Company Headquarters &  
Production Site

**E+E Elektronik Ges.m.b.H.**  
Langwiesen 7  
4209 Engerwitzdorf | Austria  
T +43 7235 605-0  
F +43 7235 605-8  
info@epluse.com  
www.epluse.com

Subsidiaries

**E+E Sensor Technology (Shanghai) Co., Ltd.**  
T +86 21 6117 6129  
info@epluse.cn

**E+E Elektronik France SARL**  
T +33 4 74 72 35 82  
info.fr@epluse.com

**E+E Elektronik Deutschland GmbH**  
T +49 6171 69411-0  
info.de@epluse.com

**E+E Elektronik India Private Limited**  
T +91 990 440 5400  
info.in@epluse.com

**E+E Elektronik Italia S.r.l.**  
T +39 02 2707 86 36  
info.it@epluse.com

**E+E Elektronik Korea Ltd.**  
T +82 31 732 6050  
info.kr@epluse.com

**E+E Elektronik Corporation**  
T +1 847 490 0520  
info.us@epluse.com



—  
your partner  
in sensor  
technology.